



LED Touch Screen Command Center
with security pass code to begin operation.



Briquettes are collected in two bottom trays. Between 1400 and 1800 soiled trays are easily loaded and processed daily. Briquette below contains over 600 densified polystyrene trays.



Tap & Stack SmartCart is used for polystyrene tray collection.
10^{3/4}" W X 25" L X 39^{3/16}" H



Briquettes measure approximately 16" X 20" and are between 2"-4" thick, weighing 12-15lbs on average.



- ✓ **REDUCE WASTE COSTS BY 50%**
- ✓ **ROI IN 2-3 YEARS!**
- ✓ **KEEP LUNCH TRAY COSTS LOW & RECYCLE 100% OF THE TRAYS!**

StyroGenie SG-1200 Specification Sheet

Benefits:

- Recycles polystyrene foam, reducing waste volume by 95%
- Up to 70% reduction in waste removal costs
- 100% diversion from landfill
- Quantitative CO2/GHG emissions reductions

Safety Access Control:

- The SG-1200 is includes an LED touch screen interface with password protection and automatic locking, load and discharge doors to safely prevent unauthorized access and operation.

Features:

- SG-1200 is constructed with 16 gauge type 304 #4 polished stainless steel interior and exterior
- 1400-1800 soiled tray capacity (Max)
- SG-1200 has a front facing/forward opening single door optional right or left hand opening.
- Both doors equipped with timed safety interlocks.
- Two (2) removable 14 gauge stainless steel catch pans with hemmed safety edges on all sides

Options:

- Casters in Lieu of legs
- Sorting table for collection and separation
- Tap & Stack Cart
- Start-up and Training

FSS StyroGenie is an advanced Polystyrene Densifier:

Any soiled #6 polystyrenes can be processed - trays, cups, clamshells and utensils. The briquettes are converted into PS pellets or styrene oil for repurposing.

Short Form Specification:

Constructed with 16 gauge type 304 #4 polished stainless steel interior and exterior with front facing opening single door with 3 stainless steel hinges. Door(s) to have timed safety interlocks. Will have 2 removable 14 gauge stainless steel catch pans with hemmed edges. Cabinet will be vented through interior sidewall and terminated into stainless steel collection cup. Will be controlled by intuitive pass code protected LED Command Center Touchscreen with step by step instructions for safe loading, processing and unloading. Maximum capacity up to 1800 lightly soiled polystyrene foam trays. Processing time varies contingent upon how full the unit is and the amount of food waste. Has a 4 digit pass code to prevent unauthorized access and operation. Has redundant high limit temperature sensors to prevent overheating with "Safe to Open" message from Command Center. Listed and labeled by Intertek. 120v, 18.8 amps. 25 amp circuit minimum, 8 foot cord and NEMA 5-20P plug. Castors or legs.

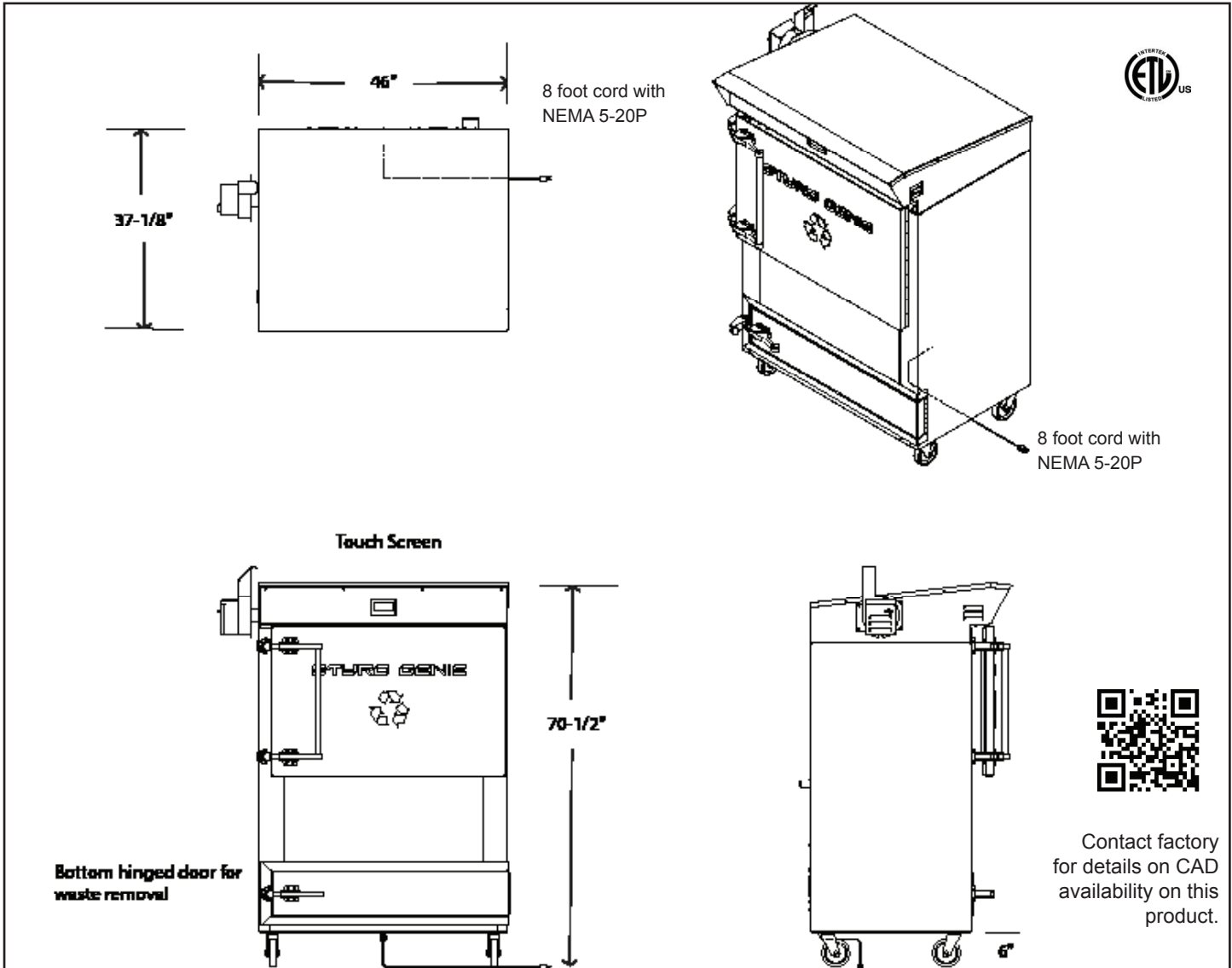

Model	Tray Capacity	Dimensions/Crated				Electrical		Processing Time
		Length	Depth	Height	Weight	Volts	Amps	
SG-1200	1800	46"	37-1/8"	70-1/2"	750lbs	120v	18.8 Amps 25 amp circuit minimum 8 Foot Cord & NEMA 5-20P plug.	8 hrs maximum
		62"	44"	78"	905lbs			

Warranty:

- Includes One-year parts and labor warranty.
- Optional Extended Warranty also available.

StyroGenie Air Emissions:

StyroGenie air emissions from thermal densification process have been 3rd party tested by two independent labs. All testing concluded that emissions met both the air quality standards of AIHA and the NELAC. Additionally, the StyroGenie meets emission standards of Cal/OSHA PEL (Permissible Emissions Limits).

Foodservice Sustainability Solutions

2106 Moon Station Drive, Kennesaw, GA 30144

info@fs-sustainability.com

www.fs-sustainability.com

Printed in the USA 11.2022

Empowering Zero Waste!

