



## Food Waste Dehydrator Specification Sheet

Provides on-site reduction of food waste volume - up to 90%. The residual dried food waste (DFW) can be used as either a valuable compost feedstock or in animal feed. The DFW provides nitrogen as part of a finished compost, which must be blended with carbon sources (often wood chips) to create a stable, finished compost. As a key material for use in animal feed base, it provides high crude protein. Diversion of waste away from landfills enables commercial entities to truly "close-the-loop" while avoiding the creation of noxious methane gas and reducing the number of trucks hauling garbage. We provide solutions for Commercial Food Waste Disposal, Organic Diversion Programs and Food Waste Diversion.

Lift and load angled top

LED Touch Screen interface with 4 digit password protection prevents unauthorized operation.



### Features & Benefits:

- Proprietary dehydration design with significantly lower cycle times possible.
- UV technology for improved sanitation and odor mitigation.
- Vented option eliminates need for drain and significantly reduces heat load on occupied space.

### Easy unloading

- Power activated discharge door
- Ergonomically designed to unload into 5 gallon container reducing strain on the operator.

**Access Control:** Includes LED touch screen interface with 4 digit password protection and automatic locking load and discharge doors to safety prevent unauthorized access and operation.

**Construction:** Constructed with heavy duty 1-1/2" stainless steel tube frame for long lasting strength and rigidity. Interior chamber is constructed with 12 gauge type 304 stainless steel. Exterior is constructed with 16 gauge 304 #4 polished stainless steel.

**Operation:** An automated on-site reduction of food waste, the system dehydrates food waste using an energy-efficient automated control process. The system requires no enzymes, additives or fresh water during the dehydration process.

### Options:

- Venting for elimination of drain
- Ventless - Requires drain
- Start-up and Training

### Short Form Specification:

Constructed with heavy duty 1-1/2" stainless steel tube frame for long lasting strength and rigidity. Interior chamber is constructed with 12 gauge type 304 stainless steel. Exterior is constructed with 16 gauge 304 #4 polished stainless steel. Will be controlled by intuitive pass code protected LED touch screen interface. Will have a 4 digit pass code to prevent unauthorized access and operation. Capacity differs by model number process is complete in as little as 8 hours. See Chart on back for capacity and electrical requirements by model number. It will be listed and labeled by Intertek. Stainless steel leveling legs with shock-absorbing pads.

Reusable Dried Food Waste (DFW) discharged from lower door into 5 gallon container.

Interior chamber rapidly converts food waste.

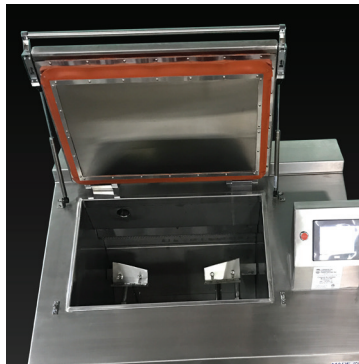

**Foodservice Sustainability Solutions, Inc.**  
2106 Moon Station Drive, Kennesaw, GA 30144  
[greenteam@fs-sustainability.com](mailto:greenteam@fs-sustainability.com)  
[www.fs-sustainability.com](http://www.fs-sustainability.com)

Printed in the USA 11.2022

**Empowering Zero Waste!**



# Food Waste Dehydrator Specification Sheet

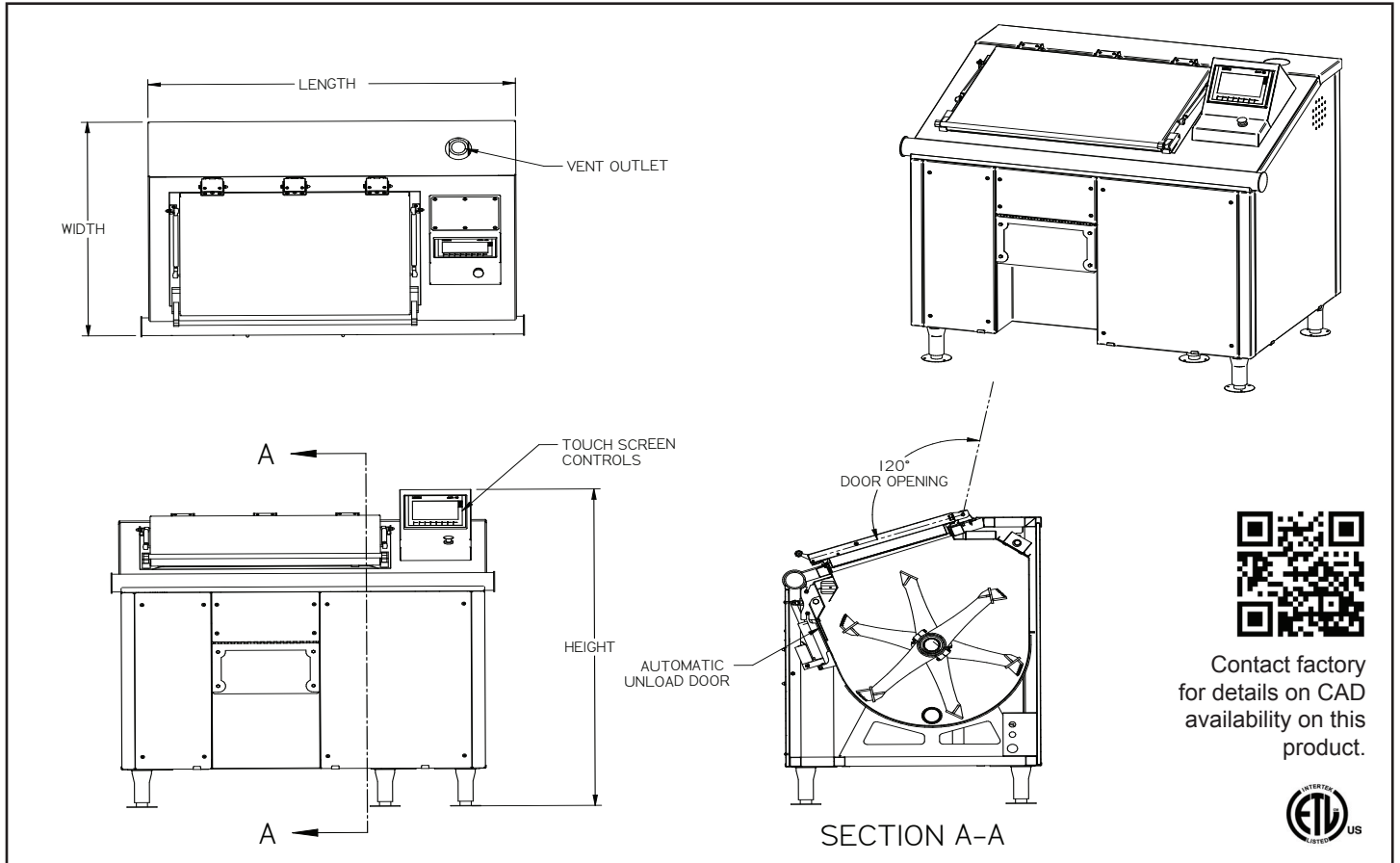

Contact factory for details on CAD availability on this product.



Model	Capacity			Diversion		Dimensions			Electrical				
	Dry System *	Cycle Time	Maximum Cycles Day	Maximum lbs/day	Tons/Month	Tons/Year	Length	Width	Height	Nominal Average kW	Volts	Service Phase	Service Breaker Size
CA-200	7-9 hrs	3	600	9	108	30"	30"	68"	5.3kW	230	1	50A-2P	38
CA-250	11-12 hrs	2	500	7.5	90	51.25"	34.5"	51"	6.37kW	230	1	60A-2P	42
CA-250	11-12 hrs	2	500	7.5	90	51.25"	34.5"	51"	6.18kW	208	3	40A-3P	26
CA-500	14-15 hrs	1.6	800	12	140	82.25"	34.5"	51"	11.22kW	208	3	60A-3P	47
CA-750	16-18 hrs	1.3	1000	15	180	78.25"	53.5"	63"	15.69kW	208	3	85A-3P	66
CA-750	16-18 hrs	1.3	1000	15	180	78.25"	53.5"	63"	17.00kW	480	3	40A-3P	31
CA-1100	18-20 hrs	1.2	1320	19	230	100.25"	53.5"	63"	19.73kW	208	3	100A-3P	83
CA-1100	18-20 hrs	1.2	1320	19	230	100.25"	53.5"	63"	21.40kW	480	3	50A-3P	39

\* Model# is equivalent to the Max. lbs/cycle for each unit.

Customized larger sizes up to 2,000 lbs/cycle available upon request.

Vented and non-vented models available.

### Warranty:

- Includes One-year parts and labor warranty.
- Optional Extended Warranty.
- Optional Full Service & Maintenance Program.